

PARTS LIST			
ITEM	PART No	DESCRIPTION	QTY
1	AA3146	CONNECTOR MALE 1/8"NPT x 1/4" TUBE	1
2	AA3195	FITTING PLUG 1/4" SS A4 - SWAGelok SS-400-P	1
3	AA7426	VALVE RELIEF 30psi (3/4"NPT)	1
4	AC8683	SENSOR L JW 0220 N 0.3H 1 1882 REV 2	1
5	AC9793	TOP PLATE - 6L COMPENSATOR	1
6	AC9794	HOUSING UPPER - 6L COMPENSATOR	1
7	AC9795	FLANGE COUPLING UPPER - 6L COMPENSATOR	1
8	AC9796	FLANGE COUPLING LOWER - 6L COMPENSATOR	1
9	AC9797	HOUSING LOWER - 6L COMP	1
10	AC9798	BASE PLATE - 6L COMPENSATOR	1
11	AC9799	DIAPHRAGM - 6L COMPENSATOR	1
12	AC9800	TIE BAR - 6L COMP	6
13	AD0213	HOUSING TRANSDUCER	1
14	AD0293	CAP PLATE SENSOR HOUSING	1
15	AD0541	SEAL O-RING 41.5 x 3.0 NBR70	1
16	AD0710	PISTON - 6L COMPENSATOR	1
17	AD0713	RETAINER DIAPHRAGM - 6L COMPENSATOR	1
18	AD1227	SEAL O-RING / 6.99 x 196.22	2
19	AD8677	SPRING 6L RESERVOIR (HIGH PRESSURE)	1
20	AJ7205	LABEL CURVETECH LOGO (BLACK ON TRANSPARENT)	2
21	AJ7481	LABEL WARNING SPRING UNDER COMPRESSION	1
22	AJ8833	LABEL 6L COMPENSATOR LEVEL	2
23	PA0078	NUT M6 NYLOC SS A2-70	24
24	PA0192	BOLT M6 x 25 SHCS SS A2-70	4
25	PA0546	WASHER M6 FLAT BS4320 FORM B SS A2	36
26	PB7913	SEAL O-RING 84.3 x 5.7	1
27	PB9837	BOLT M6 x 60 SHCS SS A2-70	12
28	PE1755	SEAL O-RING 74.5 X 3.0	1

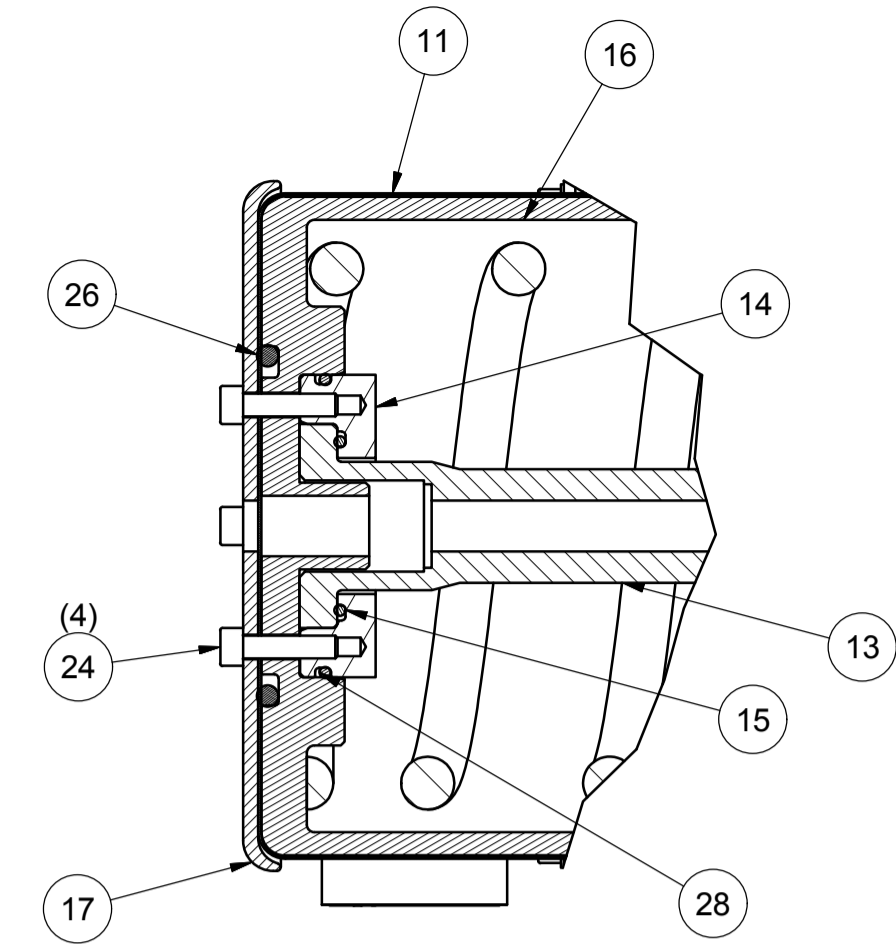
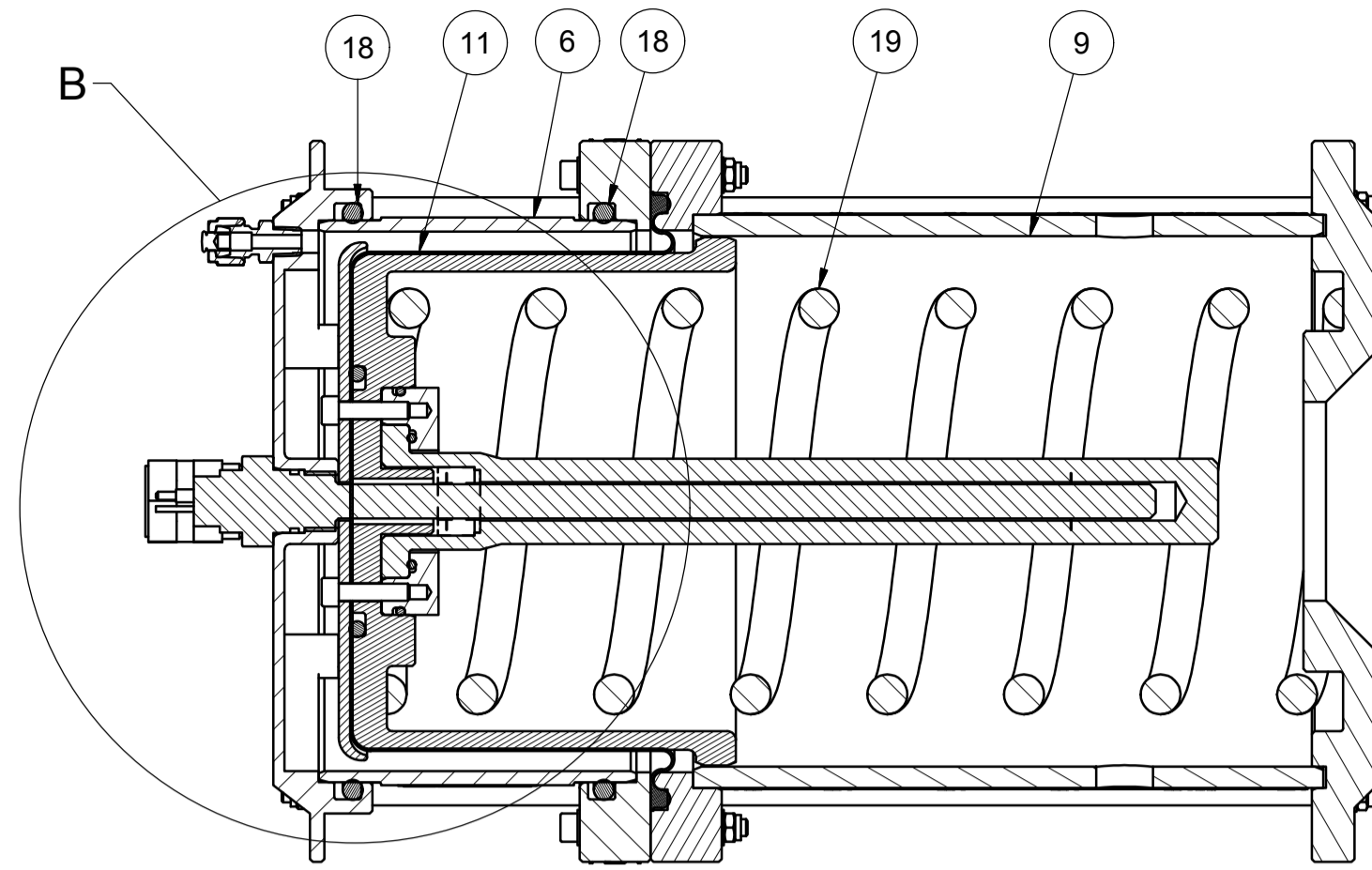

SECTION A-A

DETAIL B
(1:2)

WARNING ! DANGER OF INJURY.
 CARE MUST BE TAKEN WHEN FITTING OR REMOVING SPRING.
 A HYDRAULIC PRESS WITH RELEVANT SAFETY FEATURES OR SMD
 COMPRESSION TOOL (AJ7395) SHOULD BE USED TO COMPRESS OR RELEASE THE SPRING.

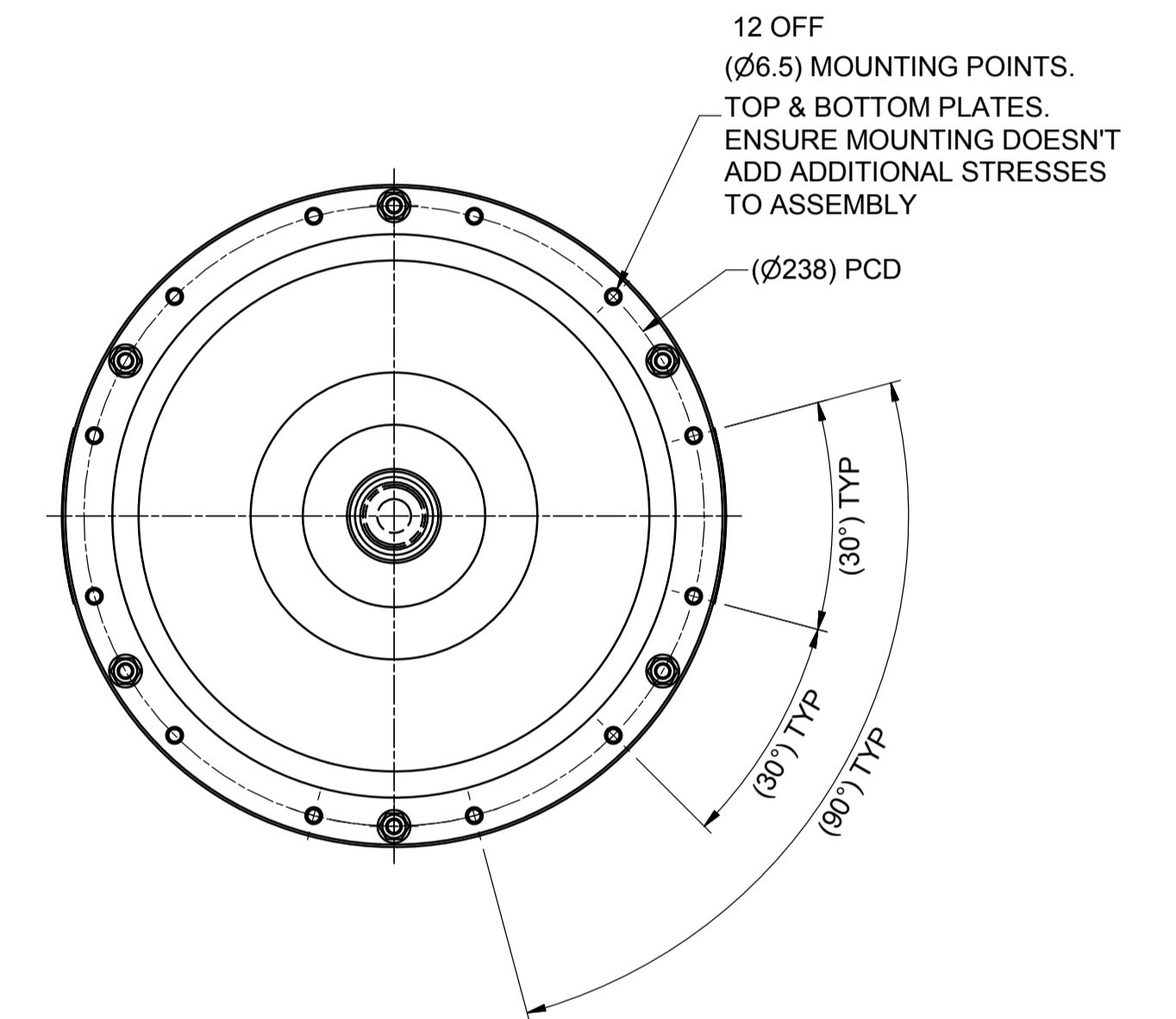
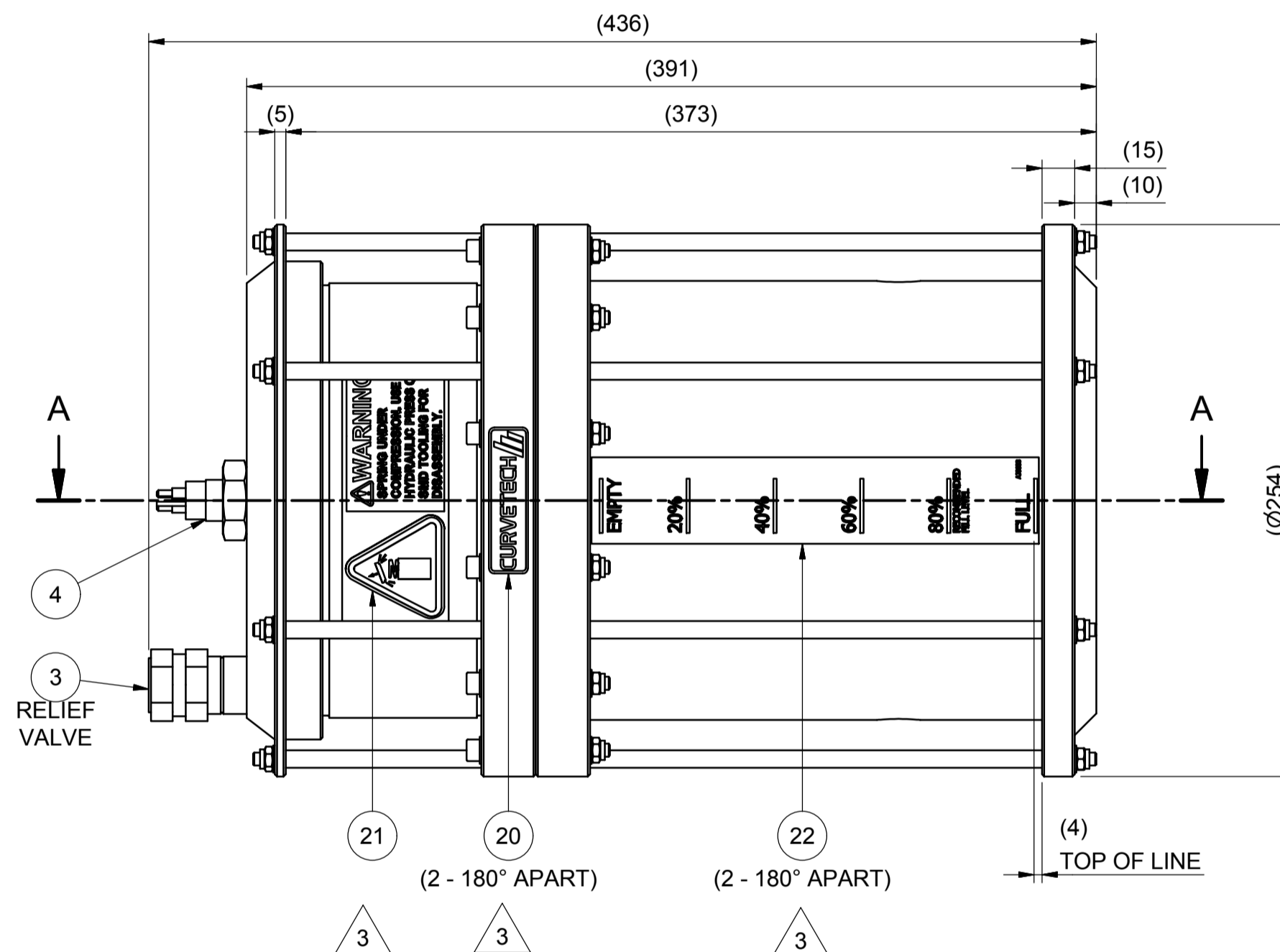
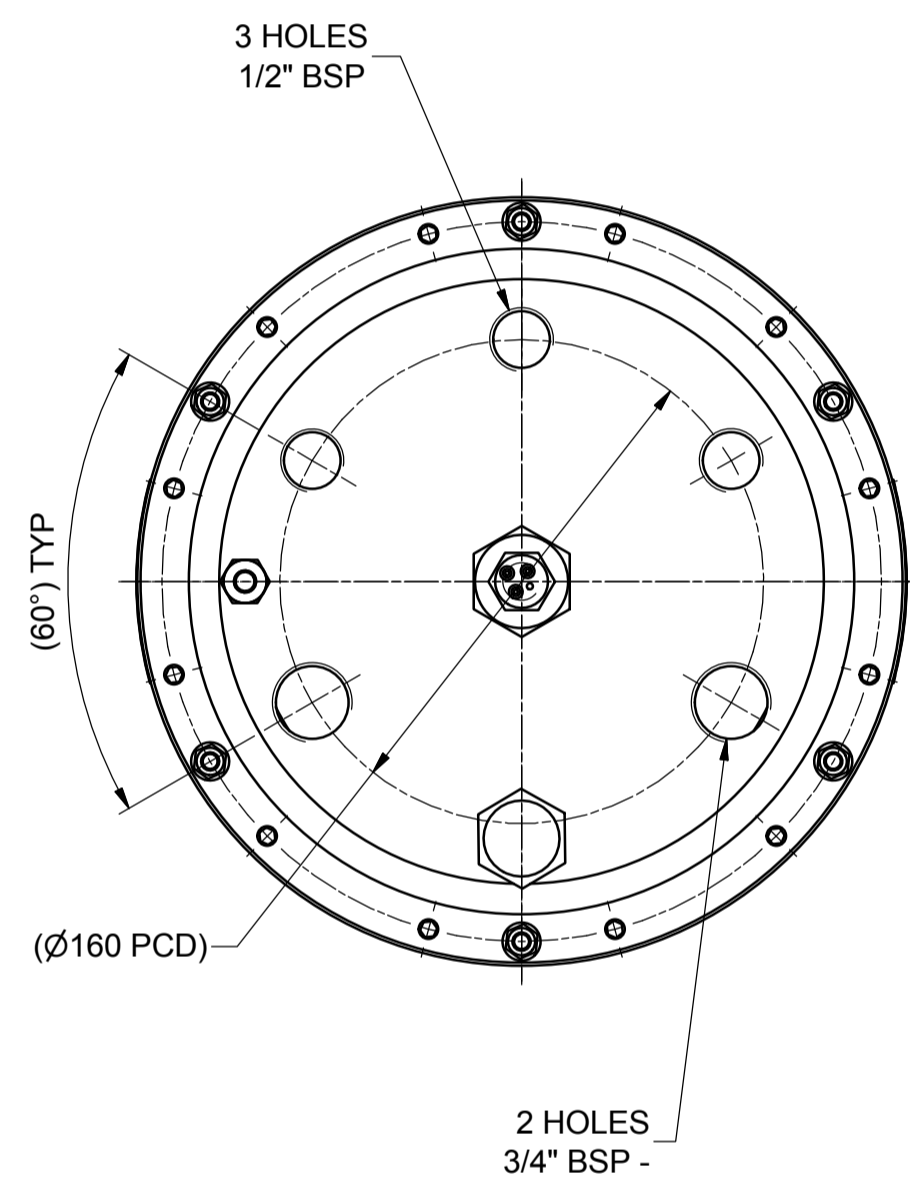
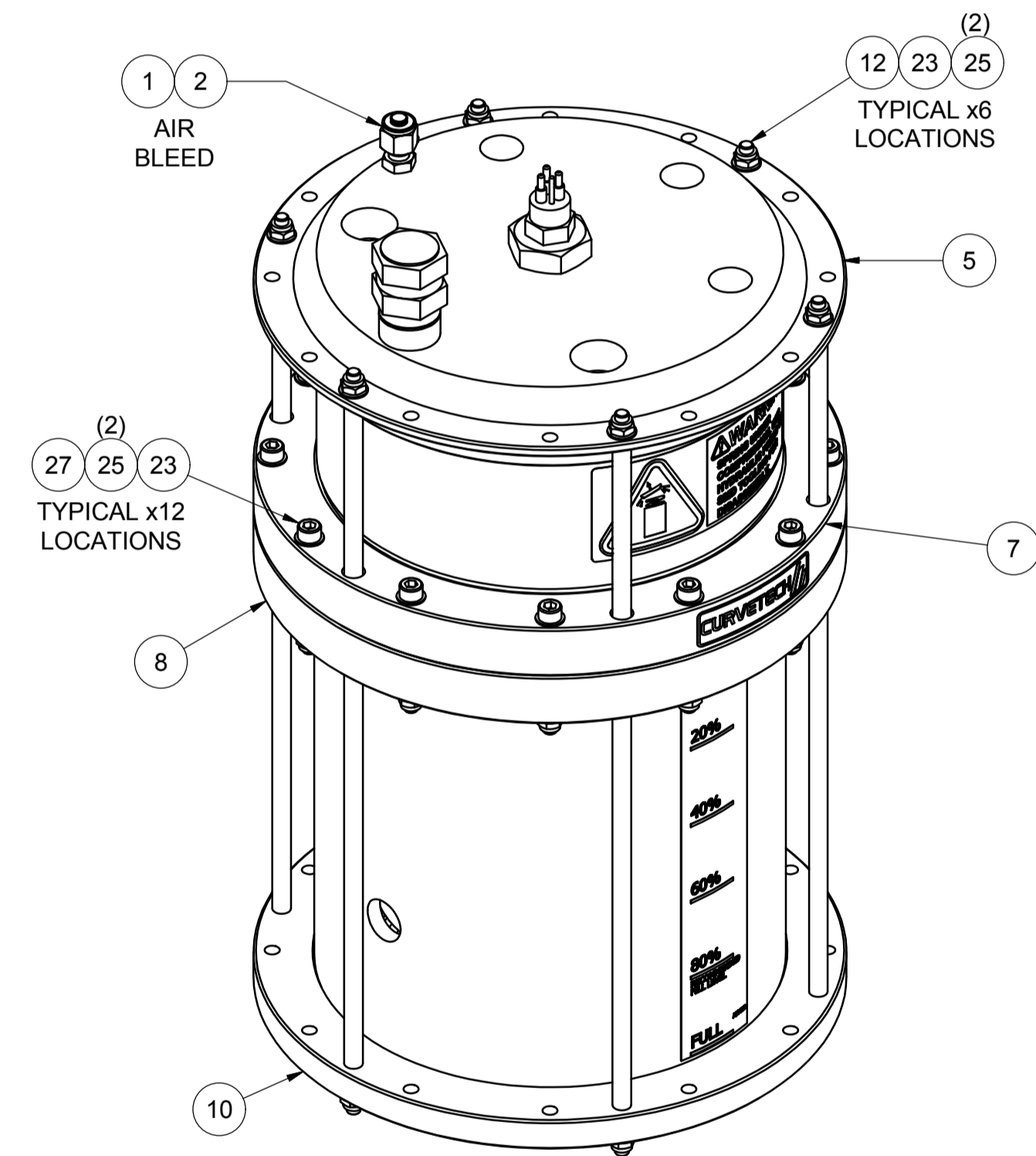

- NOTES :-
 1. ASSEMBLE IN ACCORDANCE WITH SMD SPECIFICATION W100.
 2. APPLY MOLYKOTE GREASE ON 'O-RINGS' & APPLY AQUALUBE GREASE TO ALL THREADS.
 3. BLANK ALL PORTS AFTER BUILD
 4. IF IN DOUBT PLEASE ASK.

SPECIFICATION (ESTIMATE)		
WEIGHT	IN AIR	17.1 kg
	IN WATER	11.4 kg
	IN AIR WITH OIL	22.3 kg
	IN SEA WATER WITH OIL	10.4 kg
VOLUME	FULL	6 Litre
	EMPTY	0 Litre
PRESSURE	FULL	1.6 bar
	EMPTY	0.2 bar

TRANSDUCER - SUBCONN MCBH3M-SS	
PIN	FUNCTION
1	COMMON
2	SIGNAL (0.5 - 10V)
3	INPUT (16.5 - 28V)

REV	DATE	CHANGE COMMENT	ZONE	DRAWN	CHECKED	APPD	DATE	EST. MASS	DIMENSIONS	SCALE	PROJECTION 3RD	TITLE
1	22 MAY 14	ITEM PF7562 REPLACED BY PA0192	C2	LO	DAL	DAL	14 DEC 10	17 kg	mm	1:2.5	☉	ASSEMBLY COMPENSATOR 6L - BSP - 4-24
2	25 JUL 14	AA3195 & AA3146 ADDED. BORDERS UPDATED.	-	TOB	JCUR	NRC						PSI - SUBCONN3 (IMPULSE) - 0-10V
3	03 OCT 16	DECALS AND SPEC TABLES ADDED AND FULL SECTION VIEW ADDED.	VAR	LO	PM	MvZ						

DESIGNED	DRAWN	TOLERANCES UNLESS OTHERWISE STATED	MATERIAL:-
JPG/H.R.	H.RYLE	UP TO 100 ±1.0	N/A
CHECKED <td>APPROVED <td>100 TO 300 ±1.5</td> <td>DO NOT SCALE</td> </td>	APPROVED <td>100 TO 300 ±1.5</td> <td>DO NOT SCALE</td>	100 TO 300 ±1.5	DO NOT SCALE
GJP	JPG	300 TO 1000 ±2.0	IF IN DOUBT ASK
		OVER 1000 ±3.0	
		MACHINED PART ±0.15 ±0.4 ±0.8 ±1.0	

DRAWING No	REV No.	SIZE
EV_4006-9	3	A1

SHEET 1 OF 1

ALL INTELLECTUAL PROPERTY RIGHTS SUBSISTING IN THESE DESIGNS ARE THE PROPERTY OF SOIL MACHINE DYNAMICS LTD.
 NO COPY IS TO BE MADE WITHOUT THE WRITTEN PERMISSION OF SOIL MACHINE DYNAMICS LTD. ANY PATENT APPLICATIONS,
 PATENTS AND / OR DESIGN APPLICATIONS, REGISTERED DESIGNS, DESIGN RIGHTS OR COPYRIGHT ARISING FROM OR CONTAINED IN THE
 DESIGNS ARE THE PROPERTY OF SOIL MACHINE DYNAMICS LTD. AND ALL INFORMATION MUST BE HELD IN THE STRICTEST CONFIDENCE

SMD Soil Machine Dynamics Ltd