

1

2

3

4

5

A

B

C

D

E

COUNTER-SUNK BOLT LOCATION NOT CRITICAL - CAPTIVE NUT PLATE CAN SWING TO ACCOMODATE TOLERANCE.

MAXIMISE PLATE SUPPORT UNDER HANDLE WHEN SUPPORTING VERTICALLY ORIENTATED COMPENSATOR

8 THK MAXIMUM UPPER SUPPORT PLT SEE NOTES

8 THK MAXIMUM LOWER SUPPORT PLT SEE NOTES

6 4 TYP x2 LOCATIONS

8 6 5 TYP x2 PLACES

ISOMETRIC VIEW SHOWING KIT SUPPLIED ITEMS

ISOMETRIC VIEW ASSEMBLY SHOWING 2.75L COMPENSATOR AS REFERENCE

425 + 10.0 (SEE NOTES)  
+ 1.0

**NOTES :-**

1. ASSEMBLE IN ACCORDANCE WITH SMD SPECIFICATION SMDW100
2. MOUNT CAN BE USED TO LOCATE COMPENSATOR IN HORIZONTAL OR VERTICAL ORIENTATIONS.
3. VERTICAL ORIENTATION - COMPENSATOR WEIGHT SHOULD BE TAKEN BY HANDLE END
4. ASSEMBLY IS SUITABLE FOR 2.75L COMPENSATORS WITH DUAL SPRINGS (HIGHER PRESSURE)
5. IF USING WITH THICKER MOUNTING PLATES REPLACE FASTENERS WITH LONGER VARIANTS

**QUICK INSTALLATION / REMOVAL NOTES**

- A. LOCATE COMPENSATOR OVER BOTTOM CIRCULAR MOUNT
- B. LOWER COMPENSATOR ONTO MOUNT SO HANDLE LOCATES ON THE SINGLE UPPER BOLT
- C. TWIST COMPENSATOR AND TIGHTEN SINGLE UPPER BOLT
- D. TO REMOVE FOLLOW PROCEDURE IN REVERSE

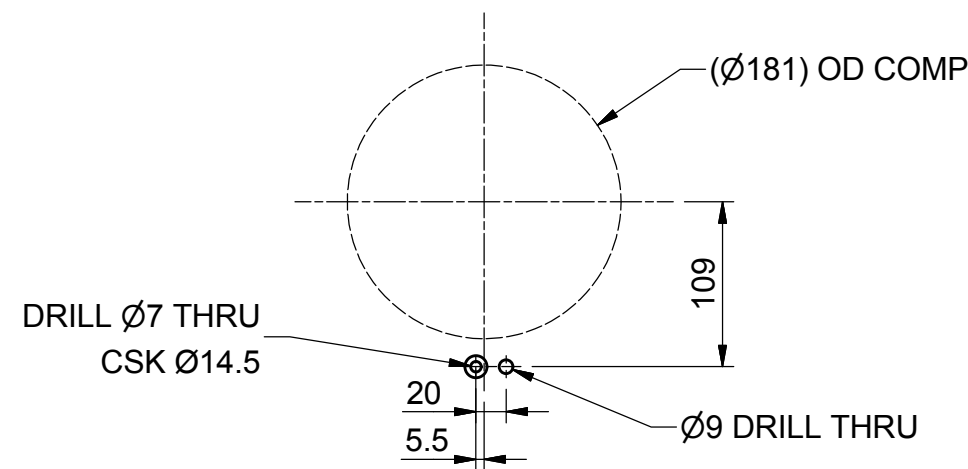

SECTION A-A  
LOCK PLATE DRILLING

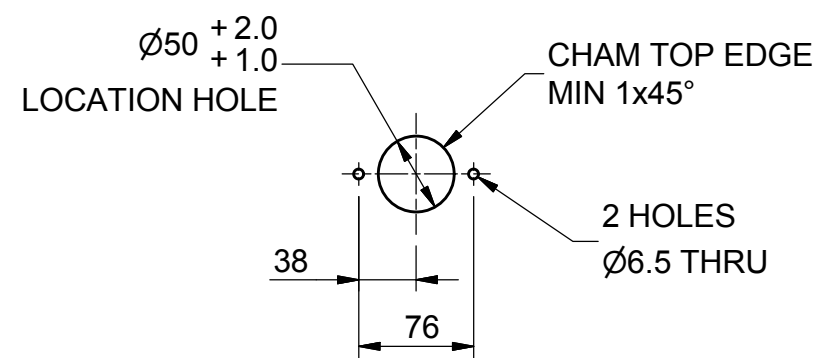

SECTION B-B  
LOWER MOUNT DRILLING

REV	DATE	CHANGE COMMENT	ZONE	DRAWN	CHECKED	APPD	DATE	EST. MASS	DIMENSIONS	SCALE	PROJECTION 3RD	TITLE	
							10 AUG 16	N/A	mm	1:5		ASSEMBLY 2.75L (DUAL SPRING) COMPENSATOR MOUNTING KIT	
									TOLERANCES UNLESS OTHERWISE STATED				
									DIMENSIONS mm	UP TO 100	100 TO 300	300 TO 1000	OVER 1000
									FABRICATION	± 1.0	± 1.5	± 2.0	± 3.0
									MACHINED PART	± 0.15	± 0.4	± 0.8	± 1.0

PARTS LIST			
ITEM	PART No	DESCRIPTION	QTY
1	AD1328	PLATE CAPTIVE NUT M8	1
2	AF6137	FABRICATION COMP MOUNT	1
3	AG4940	BOSS COMP BRACKET	1
4	OB_1212	BOLT M6 x 15 SHCS SS A2-70	2
5	PA0078	NUT M6 NYLOC SS A2-70	2
6	PA0546	WASHER M6 FLAT BS4320 FORM B SS A2	4
7	PB5117	BOLT M8 x 25 SHCS SS A4-80	1
8	PF5839	BOLT M6 x 25 SKT CSK HD SS A2-70	2
9	WA1485	BOLT M6 X 16 SKT CSK HD SS A2-70	1

TITLE			
ASSEMBLY 2.75L (DUAL SPRING) COMPENSATOR MOUNTING KIT			
MATERIAL:- N/A			
DO NOT SCALE IF IN DOUBT ASK	DRAWING No	REV No.	SIZE
	AJ9157	0	A2

ALL INTELLECTUAL PROPERTY RIGHTS SUBSISTING IN THESE DESIGNS ARE THE PROPERTY OF SOIL MACHINE DYNAMICS LTD. NO COPY IS TO BE MADE WITHOUT THE WRITTEN PERMISSION OF SOIL MACHINE DYNAMICS LTD. ANY PATENT APPLICATIONS, PATENTS AND / OR DESIGN APPLICATIONS, REGISTERED DESIGNS, DESIGN RIGHTS OR COPYRIGHT ARISING FROM OR CONTAINED IN THE DESIGNS ARE THE PROPERTY OF SOIL MACHINE DYNAMICS LTD. AND ALL INFORMATION MUST BE HELD IN THE STRICTEST CONFIDENCE.

**SMD** Soil Machine Dynamics Ltd

SHEET 1 OF 1